

ARCHITECTURAL WOODWORK QUALITY STANDARDS

STILE AND RAIL DOORS

SPEC CHEK INSERT

Size	Finish	Lites	Guarantee	Machining	Packaging
Thickness	Finish by	Metal	Life of job	Premachined	Poly bag
Width	Color	Wood	1 year	Mach. on job	Box
Height	Stain	Quantity	5 year	Bore cylinders	Crate
Clearances	Filler	Profile	Replace		Pallet by floor
Top	Glass Effect	Glass by	Replace/Rehang	Louvers	Mark opening #
Side	Primed	Glazed by	Who guarantees?	Size	
Bottom				Metal	Delivery
Type	Veneer	Glazing	Edge Treatment	Wood	Split delivery
Flush	Species	Tempered	Bevel	Lightproof	Off hr delivery
Flush w/Lites	Cut	Laminated	Babbet	Fusible	Store off site
Sketch Face	Flitch #	Wire	Rounded		To tailgate
P Lam Cover	Match Adj.	Beveled	Square	Label	To floor
Transoms	Core	Etched	Astragal?	None	Accepted by
		Colored		20 min	
Construction	Panel Faces	Installation	Requirements	Special	
5 ply	Cntr Bal Match	By woodworker	Door schedule	Core Blocks	
7 ply	Book Match	By GC	Elevations	Transoms	
Lumber Core	Run. Match	Touch-up	Full size details		
Chip Core	Pt. Grade	Hdwr. Instl.	Color samples	Pairs	
Mineral Core	Stn. Grade	Wiring	Veneer samples	Matching Reqd.	
Hollow Core	MDO	Repairs by	Corner samples	No match	
Match Edges					

SECTION 1400

Section 1400 Guide Specifications

Part 1. GENERAL

1.1. SECTION INCLUDES

- A. Stile and rail wood doors [and transom panels]; [and glazed] configuration; [fire rated] [and] [nonrated]
- B. [Wood door louvers]

1.2. PRODUCTS INSTALLED BUT NOT FURNISHED UNDER THIS SECTION

NOTE: LIST SECTIONS WHICH SPECIFY PRODUCTS FOR INSTALLATION IN THIS SECTION.

- **EXAMPLE** SECTION 8700 - HARDWARE

1.3. RELATED SECTIONS

- A. Wood door frames
- B. Flush Wood Doors
- C. Glazing
- D. Factory finishing
- E. Mechanical section(s)

1.4. REFERENCES

- A. Architectural Woodwork Institute AWI Quality Standards, current edition
- B. NFPA 80 - Fire Doors and Windows
- C. NFPA 252 - Fire Tests for Door Assemblies
- D. ASTM E152 - Fire Tests of Door Assemblies
- E. UL 10B - Fire Tests of Door Assemblies

1.5. SUBMITTALS

- A. Submit under provisions of Section []
- B. Shop drawings:
 - Submit two copies; one of which will be returned with reviewed notations prior to commencement of work under this section
 - Indicate door opening criteria, elevations, sizes, types, swings, [undercuts required,] [special beveling,] [special blocking for hardware,] and cutouts for [glazing] [louvers] [and] [_____]
 - Indicate plans and elevations, materials, profiles, assembly methods, joint details, fastening methods, accessories, hardware, and schedule of finishes
 - Indicate door core material[s] and AWI construction type; [veneer species,] [high pressure decorative laminate selection,] [factory machining criteria,] [factory finishing criteria,] [and] [_____]
- C. Samples:

NOTE: VARIATIONS IN NATURAL WOOD PRODUCTS

WOOD IS A NATURAL MATERIAL, WITH VARIATIONS IN COLOR, TEXTURE AND FIGURE. THESE VARIATIONS ARE INFLUENCED BY THE NATURAL GROWING PROCESS AND ARE UNCONTROLLABLE BY THE MANUFACTURER. THE COLOR OF WOOD WITHIN A TREE VARIES BETWEEN THE "SAPWOOD" (THE OUTER LAYERS OF THE TREE WHICH CONTINUE TO TRANSPORT SAP) WHICH IS USUALLY LIGHTER IN COLOR AND THE "HEARTWOOD" (THE INNER LAYERS IN WHICH THE CELLS HAVE BECOME FILLED WITH NATURAL DEPOSITS). VARIOUS SPECIES PRODUCE DIFFERENT GRAIN PATTERNS (FIGURES) WHICH INFLUENCE THE SELECTION PROCESS. THERE WILL BE VARIATIONS OF GRAIN PATTERNS WITHIN ANY SELECTED SPECIES. THE MANUFACTURER CANNOT SELECT SOLID LUMBER CUTTINGS WITHIN A SPECIES BY GRAIN AND COLOR IN THE SAME MANNER IN WHICH VENEERS MAY BE SELECTED. THEREFORE, COLOR, TEXTURE, AND GRAIN VARIATIONS WILL OCCUR IN THE FINEST ARCHITECTURAL WOODWORKING.

- Submit one or more 200 x 250 mm [8 x 10"] samples or door construction cut from [top] [bottom] corner, illustrating expected range of door finish color and/or grain
- Submit one or more 200 x 250 mm [8 x 10"] samples illustrating expected range of [veneer color and/or grain] [high pressure decorative laminate color/pattern]

1.6. QUALITY ASSURANCE

NOTE: AWI CLASSIFIES FABRICATION QUALITY UNDER THREE GRADE NAMES: ECONOMY, CUSTOM, PREMIUM

- ARCHITECTURAL WOODWORK, BY ITS VERY NATURE, IS USED PRIMARILY IN FINE QUALITY PROJECTS. THE THREE AWI GRADES ARE ECONOMY, CUSTOM, AND PREMIUM.
- LIMITLESS DESIGN POSSIBILITIES ARE PART OF ALL THREE GRADES. A WIDE VARIETY OF LUMBER AND VENEER SPECIES, ALONG WITH OVERLAYS, HIGH PRESSURE LAMINATES, FACTORY FINISHES, AND PROFILES ARE AVAILABLE IN ALL THREE GRADES.

•ECONOMY GRADE

- THE GRADE WHICH DEFINES THE MINIMUM EXPECTATION OF QUALITY, WORKMANSHIP, MATERIALS, AND INSTALLATION WITHIN THE SCOPE OF AWI STANDARDS.

•CUSTOM GRADE

- THE GRADE SPECIFIED FOR MOST HIGH QUALITY ARCHITECTURAL WOODWORK. THIS GRADE PROVIDES A WELL DEFINED DEGREE OF CONTROL OVER THE QUALITY OF WORKMANSHIP, MATERIALS AND INSTALLATION OF A PROJECT. THE VAST MAJORITY OF ALL WORK COMPLIES WITH CUSTOM GRADE.

• PREMIUM GRADE

- THE GRADE SPECIFIED WHEN THE HIGHEST DEGREE OF CONTROL OVER THE QUALITY OF THE EXECUTION OF THE DESIGN INTENT, AND THE QUALITY OF THE MATERIALS, WORKMANSHIP, AND INSTALLATION UNDER THIS STANDARD IS REQUIRED. USUALLY RESERVED FOR SPECIAL PROJECTS, OR FEATURE AREAS WITHIN A PROJECT.

• PREVAILING GRADE

- WHEN THE AWI QUALITY STANDARDS ARE REFERENCED AS A PART OF THE CONTRACT DOCUMENTS AND NO GRADE IS SPECIFIED, AWI CUSTOM GRADE STANDARDS WILL PREVAIL.

• EXCEPTIONS TO GRADE

- AWI RECOGNIZES THE EXCEPTIONAL NATURE OF SOME PROJECTS. THESE STANDARDS ARE INTENDED AS A GUIDE FROM WHICH THE DESIGN PROFESSIONAL IS ENCOURAGED TO EXPAND, OFTEN WITH THE ADVICE OF AN AWI MANUFACTURER. THE RESULTING PRODUCTS OFTEN EXCEED PARTS OF THIS STANDARD IN DESIGN, ENGINEERING, WORKMANSHIP, BEAUTY, AND FUNCTION.

- A. Perform work in accordance with AWI [] Grade quality
- B. Work in this Section shall comply with the specified Grade(s) or Work and Section (s) of the current edition of the Architectural Woodwork Institute Quality Standards
- C. Woodwork manufacturers shall be certified by the AWI Quality Certification Program as competent to perform the work specified
- D. Certification shall be evidenced through the application of AWI Quality Certification labels and/or the issuance of an AWI letter of licensing for the project

NOTE: CALL AWI QUALITY CERTIFICATION PROGRAM (800) 449-8811 FOR PROJECT REGISTRATION NUMBER. THERE IS NO COST TO THE DESIGN PROFESSIONAL OR OWNER FOR REGISTRATION. IF REGISTRATION IS NOT ELECTED, SUBSTITUTE THE FOLLOWING FOR SECTION 1.6 ABOVE.

1.7. QUALIFICATIONS

- A. Contractors and their personnel engaged in the work shall be able to demonstrate successful experience with work of comparable extent, complexity and quality to that shown and specified.
- B. As documentation, manufacturer shall submit neutral Prequalification Form found in the Appendix in the AWI Quality Standards, current edition
- C. Manufacturer shall be a member in good standing of the Architectural Woodwork Institute

1.8. REGULATORY REQUIREMENTS

- A. Fire Door [and Panel] Construction: Conform to [ASTM E152] [NFPA 252] [UL 10B]
- B. Installed Fire Rated Door [and Transom Panel] Assembly: Conform to [NFPA 80] [] for fire rated class [as scheduled] [as indicated]

1.9. PRE-INSTALLATION CONFERENCE

- A. Convene [] week(s) prior to commencing work of this section, under provisions of Section []

1.10. DELIVERY, STORAGE AND HANDLING

- A. Deliver, store and handle products to site under provisions of Section []
- B. Protect units from moisture damage according to AWI Quality Standards, Section 1700, Installation
- C. Protect doors with resilient packaging [sealed with heat-shrunk plastic]. Do not store in damp or wet areas; or in areas where sunlight might bleach veneer. Seal top and bottom edges upon receipt. Break seals on-site to permit ventilation

1.11. FIELD MEASUREMENTS

- A. Verify that field measurements are as indicated on shop drawings

1.12. COORDINATION

- A. Coordinate work under provisions of Section []
- B. Coordinate work with applicable mechanical trades and rough-in

Part 2. PRODUCTS

2.1. MANUFACTURERS

NOTE: LIST ACCEPTABLE MANUFACTURERS FOR THIS PROJECT.

- A. Acceptable manufacturers shall be members in good standing of the Architectural Woodwork Institute
- B. Acceptable manufacturers shall be licensed by the AWI Quality Certification Program to perform work in this Section of the AWI Grade of Work specified

2.2. DOOR [AND TRANSOM PANEL] TYPES

- A. Exterior Doors: [1-3/4] [2-1/4] inches ([44] [57] mm) thick; [solid lumber] [veneer/lumber] construction, AWI-type construction as indicated
- B. Interior Doors: [1-3/4] [2-1/4] inches ([44] [57] mm) thick; [solid lumber] [veneer/lumber] construction, AWI-type construction, [fire rated] [acoustic rated] as indicated
- C. [Transom Panels: [To match door] [____], face veneer to [end] [____] match] [fire rated] [acoustic rated] as indicated]]

2.3. DOOR [AND TRANSOM PANEL] CONSTRUCTION

- A. STILE AND RAIL: AWI Quality Standards Section 1400, Type [low-density lumber core, thick veneer] [low-density lumber core, thin veneer with crossband] [solid lumber] [two-piece face laminated solid] [three-piece face laminated solid].
- B. PANEL CONSTRUCTION: AWI Quality Standards Section 1400, Type [flat panel product] [rim raised veneer panel] [3-ply lumber raised panel] [2-ply lumber raised panel] [solid lumber raised panel]
- C. PANEL AND GLASS RETENTION: AWI Quality Standards Section 1400, Type [flat bead stop] [moulded stop] [lipped moulding] [inset moulding]

2.4. DOOR FACING

- A. Veneer Facing: _____ species wood [rotary] [plain] quarter] sliced; [book] [slip] matched leaves; [running] [balanced] [center balanced] faces, for [paint] [transparent] finish
- B. Plastic Laminate Facing: General Purpose HGS [____] finish; [____] color, [____] pattern by [____] manufacturer
- C. Cross Banding behind Plastic Laminate: One ply of mat-formed one-piece industry standard crossband.

2.5. ADHESIVE

- A. Type I (waterproof) for exterior doors
- B. Type II (water resistant) for interior doors

2.6. ACCESSORIES

- A. Wood louvers as furnished by door manufacturer
- B. Metal louvers as specified in Section 10255
- C. Glazing Stops: [Wood of same species as door facing when commonly available; compatible species for unusual veneers] [Wood with metal clips for rated doors] [Rolled steel] [Aluminum] [channel] [____] shape; [butted] [mitered] corners; prepared for countersink style [tamperproof] screws

2.7. FABRICATION

- A. Fabricate nonrated doors in accordance with AWI Quality Standards
- B. Fabricate fire-rated doors in accordance with AWI Quality Standards and to [UL] [Warnock-Hersey] requirements. Attach fire rating label to door
- C. Astragals for [Fire Rated] Double Doors: [Steel,] [Wood,] [T] [____] shaped, overlapping and recessed [at face edge] [at mid-door thickness], specifically for double doors
- D. Provide lock blocks at [lock edge] [and] [top of door for closer] for hardware reinforcement
- E. Factory machine doors for finish hardware in accordance with hardware requirements and dimensions. Do not machine for surface hardware. [Provide solid blocking for through bolted hardware.]
- F. Factory pre-fit doors for frame openings and dimensions identified on shop drawings and schedules

2.8. FACTORY FINISHING

- A. Finish work in the factory in accordance with AWI Quality Standards - Section 1500
- B. Finish work to meet AWI [Economy] [Custom] [Premium] standards
 - * * * * [OR] * * * *
- B. Seal [, stain] and varnish exposed to view surfaces. Brush apply only
- B. Seal [, stain] and varnish semi-exposed to view surfaces. Brush apply only
- B. [Prime paint] [Seal] surfaces in contact with cementitious materials
 - * * * * * * * *
- C. List both the name and the number of the AWI Finish System (topcoats) to be used from Section 1500 of the AWI Quality Standards
- D. List the sheen desired from Section 1500 of the AWI Quality Standards
- E. List the effect desired from Section 1500 of the AWI Quality Standards
- F. List the special or extra steps and/or products to be used, such as bleach, distressing, filler, glaze, shading, stain, toner or washcoats

2.9. FABRICATION

- A. Fabricate to AWI [Economy] [Custom] [Premium] Standards
- B. Apply plastic laminate finish in full uninterrupted sheets consistent with manufactured sizes.
- C. [Shop glaze glass materials using the Interior [Dry] [Combination] [Wet] method specified in Section 08800]

Part 3. EXECUTION

3.1. EXAMINATION

- A. Verify adequacy of frame opening conditions
- B. Verify frame opening sizes and tolerances are acceptable and ready to receive this work

3.2. INSTALLATION

- A. Install work in accordance with AWI [Economy] [Custom] [Premium] Quality Standard
- B. Set and secure materials and components in place, plumb and level
- C. Install [fire rated] [and] [non-rated] doors in accordance with [NFPA 80] and to [UL] [Warnock-Hersey] requirements
- D. Trim nonrated door width by cutting equally on both edges
- E. Trim door height by cutting bottom edges to a maximum of ³/₄" (19 mm) [Trim fire door height at bottom edges only, and in accordance with fire rating requirements]
- F. Pilot drill screw and bolt holes
- G. Machine cut for hardware; Core for handsets and cylinders
- H. Coordinate installation of doors, frames, glass and glazing, louvers, accessories
- I. [Site glaze glass materials using the Interior [Dry] [Combination] [Wet] method specified in Section 08800]

3.3. ADJUSTING

- A. Conform to AWI Standards for fit and clearance tolerance
- B. Conform to AWI Standards and Tests for warp and telegraphing

3.4. CLEANING

- A. Clean work under provisions of [01700] []

** End **



General Information

1400-G-1

Scope

Includes:

Stile and rail doors, manufactured with solid lumber and/or panel products for a particular project.

Function, performance, and aesthetics are combined in producing a stile and rail wood door for a particular opening. Function and performance are primarily controlled by the door construction. Aesthetics are primarily controlled by species, veneer cut, matching of veneers and finish selected.

Excludes:

“Stock” commodity doors or commercial doors manufactured without the benefit of AWI Standards.

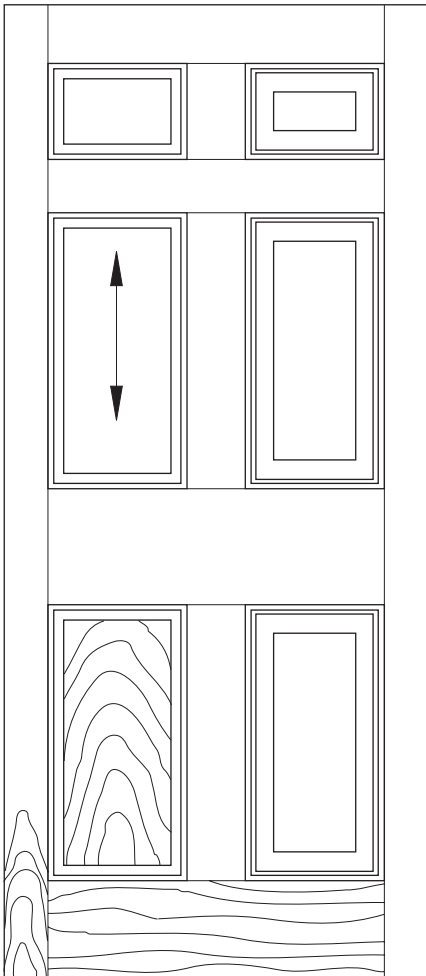

Stile and Rail Doors - Figure 1400-01

1400-G-2

Specification Requirements

GRADE MUST BE SPECIFIED

AWI Architectural Woodwork Standards provide for three grades: Premium, Custom, and Economy.

Premium Grade

The Grade specified when the highest degree of control over the quality of workmanship, materials, installation and execution of the design intent is required. Usually reserved for special projects, or feature areas within a project.

Custom Grade

The Grade specified for most conventional architectural woodwork. This Grade provides a well-defined degree of control over the quality of workmanship, materials and installation of a project. The vast majority of all work produced is Custom Grade.

Economy Grade

The Grade which defines the minimum expectation of quality, workmanship, materials, and installation within the scope of AWI Standards.

Prevailing Grade

When the AWI Quality Standards are referenced as a part of the contract documents and no grade is specified, AWI Custom Grade standards will prevail.

1400-G-3

Exterior Doors

Careful consideration must precede specification of wood doors for exterior use.

Exterior doors shall be properly sealed immediately after sizing and machining for fit in the field.

Wood doors should be protected from the sun and other weather elements by overhangs, deep recesses, etc.

Some door companies limit their warranties on exterior doors.

1400-G-4

Flashings

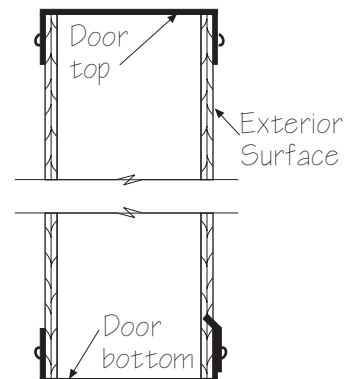

Flashing Detail - Figure 1400-02

If the woodworker is to flash the top of the door or the bottom edge of cutouts for exterior doors, it must be specified.

1400-G-5

Fire Ratings

The Model Codes have established a fire door rating and operating classification system for use in protecting door openings in fire-resistive-rated wall constructions. All fire doors must meet the requirements of ASTM E-152, and bear certifying labels of an independent testing agency approved by the building official.

1400-G-6

Factory Finishing

AWI member firms differ in the variety of factory finishes offered. Some finishes may not be available from all manufacturers.

Finishes protect wood from moisture, handling, or harsh chemicals. The sooner moisture is restricted from entering or leaving, the longer wood lasts and the finer it looks.

Transparent finishes without stain provide a protective “window” for the wood, maintaining its natural look. Transparent finishes with stain provide the architect or designer an opportunity to create a striking visual effect by modifying color, look, and sheen.

Finishing Options

Section 1500 of this Standard defines the AWI finishing systems and performance characteristics.



NOTE: Careful study of Section 1500 and consultation with your AWI woodworker early in the design phase can result in both high quality and cost savings.

Factory finishing is generally specified when a project requires high quality performance and superior appearance. Factory finishing offers many benefits, including:

- State-of-the-art equipment in a well-lighted, dust-free environment (conditions normally not available in the field), which provides uniform color, texture, and sheen.
- Proper sanding prior to the application of stains and finishes. Field conditions often hinder surface preparation resulting in a lack of clarity and uniformity in finish and color.
- Protection from unfavorable relative humidity conditions at the earliest possible time.
- Cost savings (in most cases) over the total cost of field-applied finishes by a separate contractor.
- Shorter installation time on the job site, resulting in faster project completion.

Sample Submission

AWI woodworkers often provide standard colors for selection.

To specify nonstandard colors and sheens, the architect is to provide two or more samples at least 8" x 10" showing the desired finish effect on the wood species and cut to be used.

Samples are to bear identification of the project, architect, general contractor, and door supplier. The door manufacturer may elect to submit samples in sets of two or more, illustrating the possible range of variations. The finished sample sets then become the final criteria for evaluating color and finish appearance conformity. However, variations can be expected due to the nature of wood; such as the barber-pole effect in book matching, variations from heartwood to sapwood, etc.

Sample Protection

Approved samples must be protected from the effect of light. Cover faces and place samples in closed storage during the period between approval and fabrication, finishing and delivery of the finished product.

1400-G-7

Care and Installation at Job Site

Storing

- Store flat on level surface in a clean, dry, well-ventilated area protected from sunlight.
- Some species are sensitive to light and must be covered.
- Doors should not be subjected to extremes of heat and/or humidity. Relative humidity should not be less than 25% nor more than 55%.
- Store doors in closed-in building with operational HVAC system.
- Cover doors to keep clean, but allow air circulation.
- Seal at earliest possible moment. Edge sealing is particularly important.
- Lift or carry door. Do not drag one door against another.
- Handle doors with clean hands or clean gloves.

Installation

- Allow doors to become acclimated to finished building heat and humidity before fitting and hanging.
- Utility or strength of doors must not be impaired by fitting to the opening, applying hardware, plant-ons, louvers or other detailing.
- In fitting for width, trim equally from both sides. See Fire Door Requirements (following section) for special fitting instructions on rated doors.
- In fitting for height, do not trim top or bottom edge more than 3/4" unless accommodated by additional blocking. See Fire Door Requirements (following section) for special fitting instructions on rated doors.
- Threaded-to-the-head wood screws are preferable for fastening all hardware on non-rated doors and required on all rated doors. Pilot holes must be drilled for all screws to avoid splitting.
- Use two hinges for doors up to 60" in height, three hinges for doors up to 90" in height, and an additional hinge for every additional 30" of door height or portion thereof.

Fire Door Requirements

Install doors as required by NFPA Pamphlet 80. Core reinforcements can be specified to permit hardware to be surface mounted with screws. Labels shall not be removed from fire-rated doors.

Preparation of Labeled Doors

Preparation of rated doors must be done under label service in accordance with the manufacturer's service procedure. This includes trimming for size except a maximum of $\frac{3}{4}$ " off the bottom of the door. Preparation of locks, latches, hinges, closers, lights, louvers, astragals, and any fabrication must be done under licensed label service.

1400-G-8

Construction Details

Stiles

Stiles are the vertical outside members. They may be solid wood or veneered. Stiles usually have solid sticking (solid stuck, solid moulded). Sticking is usually of two profiles: "cove and bead" or "ovolo." Other profiles may be used. The stiles are ploughed or grooved along the edge to receive the panels, rails, and/or glass. If the door is to be assembled by dowelled construction, the stiles are bored to receive the dowels. The stiles will contain much of the hardware for the door, and must be sized and fabricated to fit the intended hardware, locks, and latches.

Rails

Rails are the cross or horizontal members of the door. Rails are coped on both ends to fit the sticking of the stile. Tenons or dowels are machined into the rails to fit mortises or dowel boring in the stiles.

The top and bottom rails are required, with the addition of intermediate cross rails or lock rails as appropriate. The bottom rail is usually the widest of the members, made of edge glued lumber or veneered, depending on the door construction. The top rail is often the same face dimension as the stiles.

The lock rail, if there is one, is usually a wide member located at lock height. In the case of narrow stiles or large hardware, this rail serves to house the lock and latch mechanisms.

Mullions

The mullion is an upright or vertical member between panels. It is similar to a cross rail in the way it is fit and machined.

Panels

The door panels are either solid lumber or panel products that fill the frame formed by the stiles, rails, and mullions. When the figure of the wood is visible in the finished product, the grain direction of the panels usually runs along their longest dimension; vertical for tall panels and horizontal for wide (or laying) panels.

Muntins and Bars

Stile and rail door with glass panels often utilize muntins and bars, which are smaller in section than mullions. A bar is a rabbeted moulding which extends the total height or width of the glass opening. A muntin is a short bar, either horizontal or vertical, extending from a full bar to a stile, rail, or another bar. Muntins and bars are traditionally coped and mortised joinery.

Custom-designed stile and rail doors offer many opportunities for creativity and choice. Some of the variables include:

- Panel layout
- Grain patterns and relationships
- Stile and rail construction
- Moulding details
- Panel construction
- Joinery techniques

Selection among these variables requires some knowledge of their relative performance characteristics. The following drawings illustrate some of the options. Consult your AWI woodworker early in the design process for assistance in making selections.

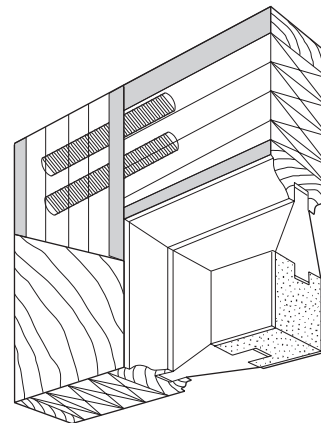

Stave lumber core with dowel joinery - Figure 1400-03

1400-G-9

Door Thickness, Panel Layout, and Grain Patterns

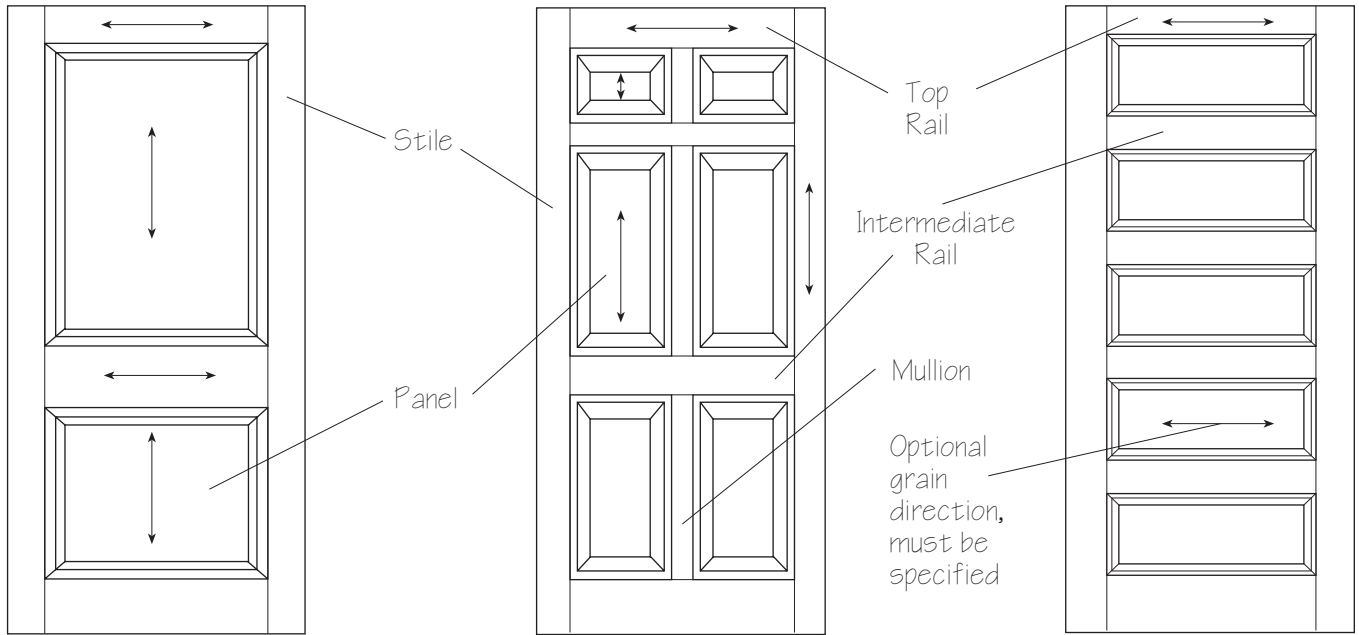

Layout and Grain - Figure 1400-04

Stile and rail doors are usually 1³/₄" thick. For doors over 3'-6" in width or 8'-0" in height, 2¹/₄" minimum thickness is recommended. Traditionally, the grain direction flows with the longest dimension of the stile, rail, or panel. Panel grain direction can sometimes be altered for design purposes, and must be specified. If raised panels are to be rim-raised veneered construction, the grain of the rims will flow around the panel with the long dimension of the rim material.

1400-G-10

Stile and Rail Construction

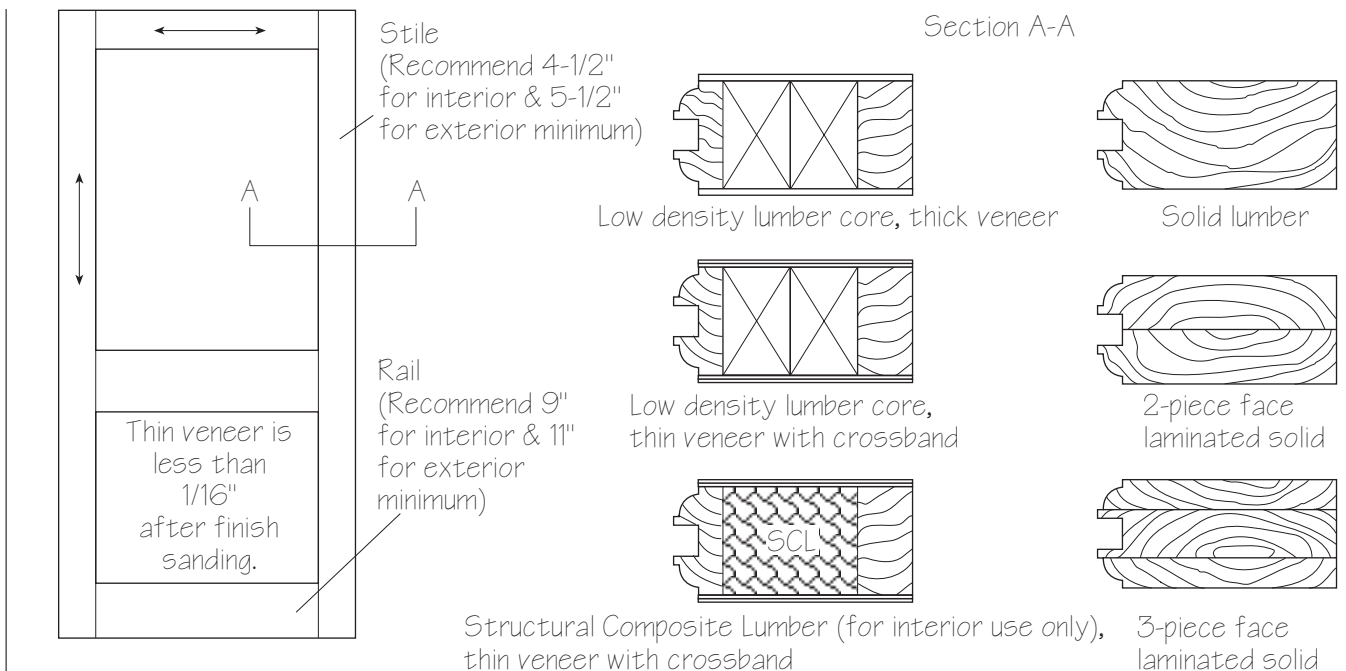

Stile and Rail Options - Figure 1400-05

There are a variety of methods of stile and rail fabrication. It is possible to fabricate stile and rail doors that will perform within the tests established in the Test Sections of this Standard using any of the illustrated techniques and others.

1400-G-11

Panel Construction

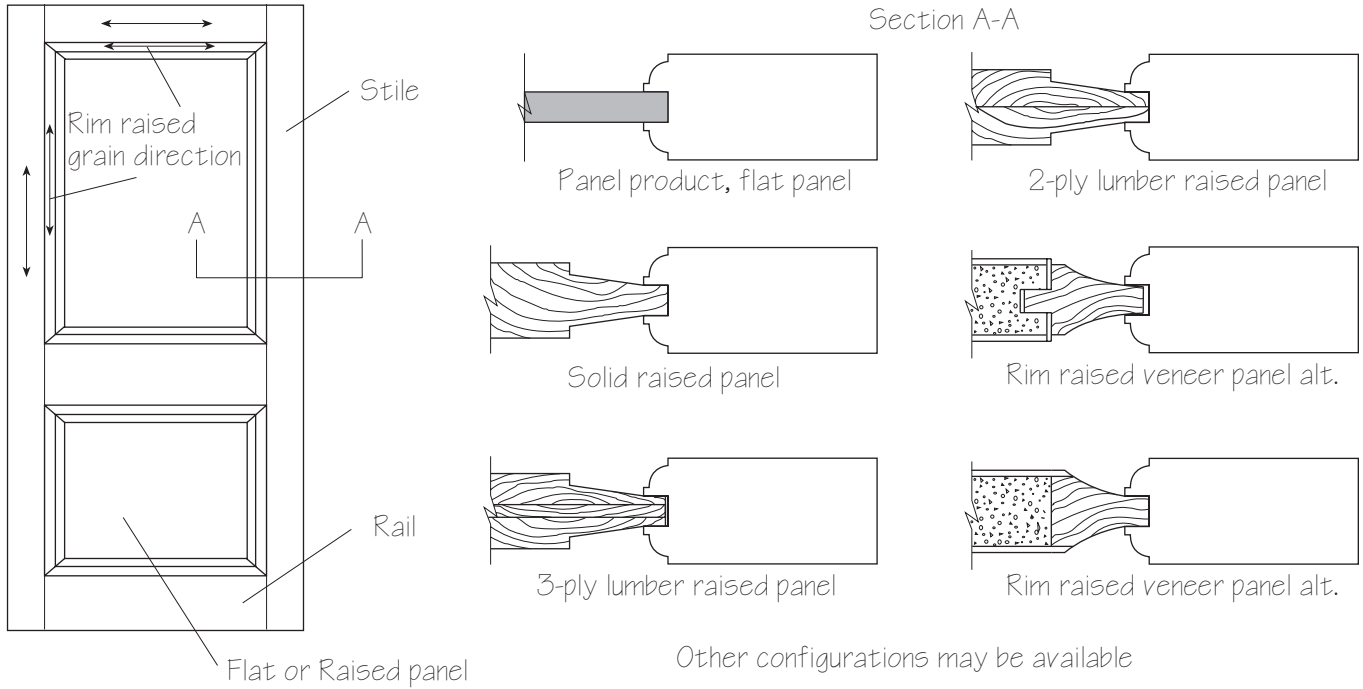

Panel options - Figure 1400-06

There are a variety of methods of flat panel and raised panel fabrication. Review the Standards in this Section for maximum allowable widths in solid or edge-glued lumber. It is possible to fabricate stile and rail doors that will perform within the tests established in the Test Sections of this Standard using any of the illustrated techniques and others.

1400-G-12

Panel and Glass Retention

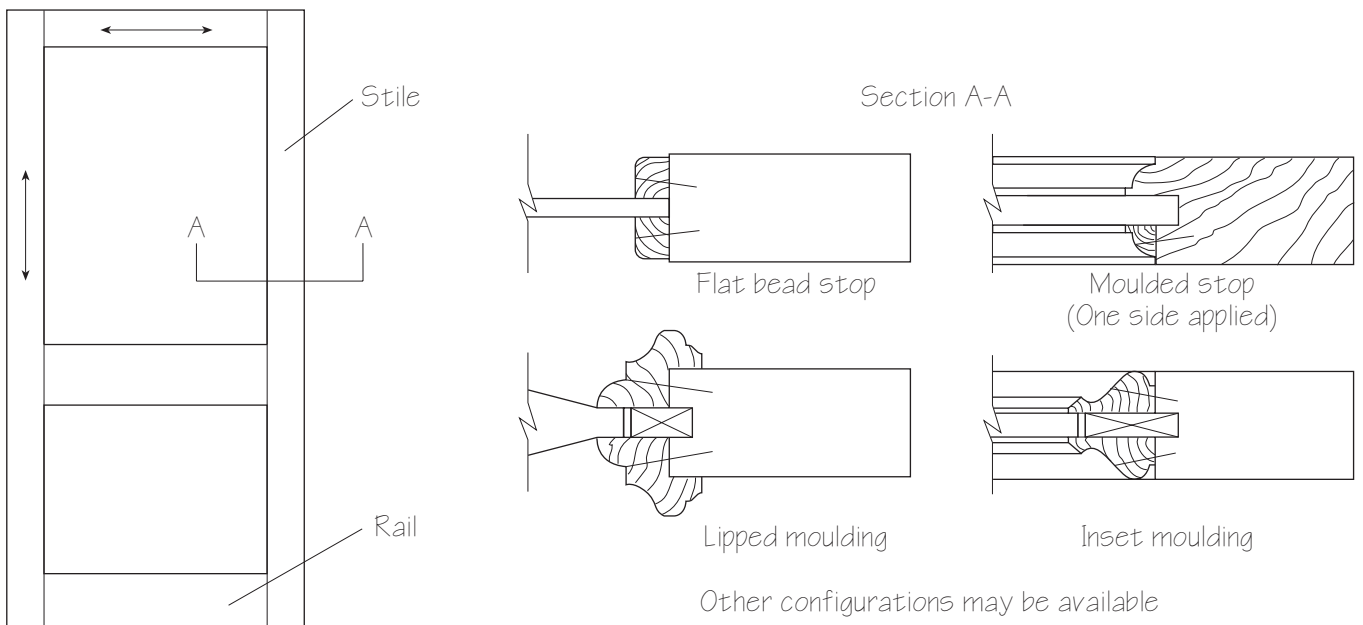

Panel and Glass details - Figure 1400-07

A wide variety of design choices are available from woodworkers. The illustrations are intended as guidelines for the design professional and should not limit the potential for creative solutions. Glass cannot always be centered on stiles and rails, depending on the thickness. Mouldings and stop are usually applied with small brads or finish nails.

1400



Standards

1400-S-1

Specification Requirements

Specific requirements for face, matching veneers, vertical edges, lights, louvers, moulding and transoms are provided in the following tables. AWI Grade must be specified.

Architect or Design Professional shall ...

- specify the AWI Grade required;
- specify the species and type of cut, if other than plain sawn;
- specify whether the panels are to be flat, rim-raised or solid;
- specify the ornamental details and joinery which affect the aesthetics and function;
- specify the preservative treatment for exterior use, if required
- specify the fire retardant rating, if required; and
- specify the fabrication techniques or door types as appropriate.

1400-S-2

Face Material Requirements

Veneers for Transparent Finishes

Premium Grade

“AA” grade faces are required for Premium Grade doors. Veneer is required to be of sufficient thickness to preclude sand-through, show-through of core, and glue bleed.

Custom Grade

“A” grade faces are required for Custom Grade doors. Veneer is required to be of sufficient thickness to preclude sand-through, show-through of core, and glue bleed.

Economy Grade

“B” grade faces are required for Economy Grade doors. Veneer is required to be of sufficient thickness to preclude sand-through, show-through of core, and glue bleed.

Solid Lumber for Transparent Finish

Premium Grade

AWI Grade I hardwood or softwood.

Custom Grade

AWI Grade II hardwood or softwood.

Economy Grade

Manufacturer’s option.

Materials for Opaque Finishes

Premium Grade

AWI Grade II hardwood or Grade I softwood lumber or sound close grain hardwood veneer, minimum “A” grade. Plain medium den-

sity fiberboard (MDF) or medium density overlay (MDO) also permitted.

Custom Grade

AWI Grade II lumber or sound close grain hardwood veneer, minimum “B” grade. Plain medium density fiberboard (MDF) or medium density overlay (MDO) also permitted.

Economy Grade

Mill option.

1400-S-3

Core Requirements (for Veneered Fabrication)

The architect/specifier is required to make a core selection depending upon the application. In some cases medium density fiberboard (MDF) core is recommended. MDF or SCL may not be used for stiles or rails unless specified. The core materials are manufactured according to the following:

Medium Density Fiberboard Core (MDF)

Medium Density Fiberboard (MDF) core is manufactured to the ANSI standard A208.2.

Structural Composite Lumber Core (SCL)

A man-made composite that utilizes wood strands from a variety of tree species providing an alternative to dimension lumber. The material is engineered for strength and stability. While not really “lumber,” it is marketed as a lumber substitute, to be used in primarily place of stave lumber core materials. SCL is tested under a number of ASTM and other test criteria. There is insufficient data to recommend SCL for exterior use.

Low Density (Staved) Lumber Core

May be a combination of blocks or strips, not more than 2^{1/2}" wide, of one species of wood at 6-9 percent moisture content. Joints to be tight and staggered in adjacent rows.

1400-S-4

Exposed Vertical Edges

Premium Grade

Same species as face, lumber, or veneer over hardwood. Joints not allowed. Sanded ease.

Custom Grade

Same species as face, lumber, or veneer, or compatible hardwood. Joints allowed on hinge edge only. Sanded ease.

Economy Grade

Manufacturer’s option.

1400-S-5

Materials

In the absence of specifications, the following standards will apply. Where more than one method or material is listed for a Grade, manufacturers will supply their choice from the alternatives.

Materials	Premium		Custom		Economy	
	Transparent	Opaque	Transparent	Opaque	Transparent	Opaque
AWI Lumber grade (see Section 100)						
Stiles, rails, mullions and applied mouldings	I well matched for grain and color between veneer and lumber	II	II compatible for color between veneer and lumber	II	II with no selection for grain or color	II
Flat panels	Not permitted, panel product required		II Permitted for panels less than 14" [350 mm] across the grain		II permitted for panels in any dimension	
Raised Panels	I Used to rim panel product centers	II Used to rim panel product centers	II Used to rim panel product centers and permitted for panels less than 14" across the grain			
It is recommended all exterior wood elements be treated with a wood preservative in accordance with Section 100 of these Standards. Due to environmental considerations, not all AWI manufacturers can treat wood products at their plant.						
AWI Panel Products (see Section 200)						
Core for veneered stiles, rails, and mullions	Low density lumber (SCL or MDF by specification)		Low density lumber, SCL or MDF		Mill option	
Core for veneered flat and raised panels	Particleboard or fiberboard (veneer core only by direct specification)		Particleboard or fiberboard (veneer core only by direct specification)	Particleboard or fiberboard recommended (veneer core permitted)	Particleboard or fiberboard recommended (veneer core permitted)	Particleboard, fiberboard or veneer core
Face veneer grade for Transparent finish and Material for opaque finish	"AA" face well matched for grain and color between veneer and lumber	"A" veneer, plain fiberboard or medium density overlay	"A" face compatible for color between veneer and lumber	"B" veneer, plain fiberboard or medium density overlay	"B" face veneer	"B" veneer, plain fiberboard or medium density overlay
Minimum Assembly Thickness						
Veneered Stiles and Rails	1-3/8" [35 mm]		1-3/8" [35 mm]		1-3/8" [35 mm]	
Flat Panels	3/8" [10 mm]		3/8" [10 mm]		1/4" [6 mm]	
Raised Panels	3/4" [19 mm]		3/4" [19 mm]		1/2" [13 mm]	

1400-S-6

Workmanship

Subject to design considerations, connecting joints between stiles, rails, and mullions shall be mortise and tenon, or doweled, and glued under pressure, using Type I glue on exterior doors. The following details and chart give a quick picture of reasonable expectations when doors are specified using the AWI Premium and Custom Grades.

Workmanship	Premium		Custom		Economy	
	Transparent	Opaque	Transparent	Opaque	Transparent	Opaque
Finish Condition	Transparent	Opaque	Transparent	Opaque	Transparent	Opaque
Cut of Lumber	Plain sawn	Plain sawn	Plain sawn	Plain sawn	Mill option	
Cut of Veneer	Plain sliced	Mill option	Plain sliced	Mill option		
Matching Considerations						
Stile and rail orientation	Top, cross & bottom rails shall run between the vertical stiles. Mullions shall run between horizontal rails. For Transparent finish, components shall be well matched for grain and color, member-to-member. No selection required for opaque finish.				Mill option	
Veneer match between adjacent leaves on a single panel face	Book match	Mill option	Book match	Mill option	Mill option	
Note on Special Matching: Book Match and End Match or Slip Match and End Match, or Special Sketch Faces must be specified and detailed in the architectural drawings. Consult an AWI manufacturer for design solutions.						
Veneer match within each panel face	Center and balance	Mill option	Running	Mill option	Mill option	
Veneer sequence between adjacent panels (Blueprint match available. See Section 200.)	Sequence match side-to-side and continuous vertically	Mill option	Selected for compatibility of grain and color	Mill option	Mill option	
Veneered panel sequence between doors (Blueprint match available. See also Section 200)	Selected for compatibility of color	Mill option	Selected for compatibility in general appearance	Mill option	Mill option	
Solid lumber panel	Not permitted		Selected for compatibility of color (transparent finish only)		Mill option	
Fiberboard or MDO panel	Permitted for opaque finish only in any Grade					
Minimum Thicknesses for 1-3/8" [35 mm] Thick Door						
Flat Panels	3/8" [10 mm]		3/8" [10 mm]		1/4" [6 mm]	
Raised Panels	3/4" [19 mm]		3/4" [19 mm]		1/2" [13 mm]	
Minimum Thicknesses for 1-3/4" [44 mm] Thick Door						
Flat Panels	1/2" [13 mm]		1/2" [13 mm]		1/2" [13 mm]	
Raised Panels	1-1/8" [29 mm]		1-1/8" [29 mm]		1-1/8" [29 mm]	
Minimum Thicknesses for 2-1/4" [57 mm] Thick Door						
Flat Panels	3/4" [19 mm]		3/4" [19 mm]		3/4" [19 mm]	
Raised Panels	1-1/2" [38 mm]		1-1/2" [38 mm]		1-1/2" [38 mm]	
NOTE: Panel products for exterior doors must have Type I glue.						

1400-S-7

Machining and Joinery

In the absence of specifications, the following standards will apply. Where more than one method or material is listed for a Grade, manufacturers will supply their choice from the alternatives.

Machining	Premium	Custom	Economy			
Plant Machining Considerations						
Door sizing	Unless otherwise specified, doors will be shipped full width and full height for field fitting. Prefitting and premachining is available from most AWI manufacturers. Doors shall be manufactured to a thickness tolerance of $\pm 1/16"$ [± 1.6 mm] of specified thickness.					
Panel retention note	Regardless of method of retention, panels must have freedom and room to expand and contract in reaction to ambient humidity changes.					
Lock clearance	Stile width must be designed to allow machining for the lock case. A minimum of 1" of stile must remain between the back of the lock case and the edge of adjacent panel or glass.					
Joinery and Assembly Considerations						
Stiles, rails, & mullions	Joined with mortise and tenon, 1/2" dowels or loose tenon joinery, glued under pressure. Moulded profiles (sticking) shall be at the option of the manufacturer, unless full size details are shown in bid documents. Involve your AWI manufacturer early in the design process.					
Solid lumber panels	Not permitted	Edge glued and planed/sanded to thickness (up to 14" [350 mm])	Edge glued and planed/sanded to thickness			
Raised panel rims	Mitered; and glued to panel body under pressure	Mitered; and glued to panel body under pressure	Mitered; and glued to panel body under pressure			
Panel product centers	Panel core must be covered by veneer or concealed by rim moulding	Panel core must be covered by veneer or concealed by rim moulding	No edge treatment required			
Applied mouldings	Plant fastened; spot glued, fine finish nailed, set, filled and sanded	Plant fastened; spot glued, fine finish nailed	Plant fastened; spot glued, fine finish nailed			
Minimum Veneer Thickness (visible surface species)						
Veneer on stile and rail	Industry standard (varies by species) of sufficient thickness to preclude show through or telegraphing of core after sanding.					
Veneer on panels						
Edge Treatments of Stiles and Rails						
Finish --->	Transparent	Opaque	Transparent	Opaque	Transparent	Opaque
Outside square edge: solid lumber (top and bottom not considered exposed edges)	All exposed edges one piece (no joints), same species as face	Mill option	All exposed edges one piece (no joints), compatible species to face	Mill option	Mill option	Mill option
Inside Moulded Edge	Permitted only in solid lumber. Profile must be capable of being coped without a feather edge.					
NOTE: Site applied mouldings are governed by Section 300 and Section 1700. The this table applies to mouldings contained wholly within an individual panel or used as rim or panel retention members. Integral Applied Moulding: Acceptable with solid or veneered stiles and rails. Mouldings must be mitered. Mouldings must be fastened to stile or rail (not to panel to permit movement), utilizing not more than two positioning nails.						

1400

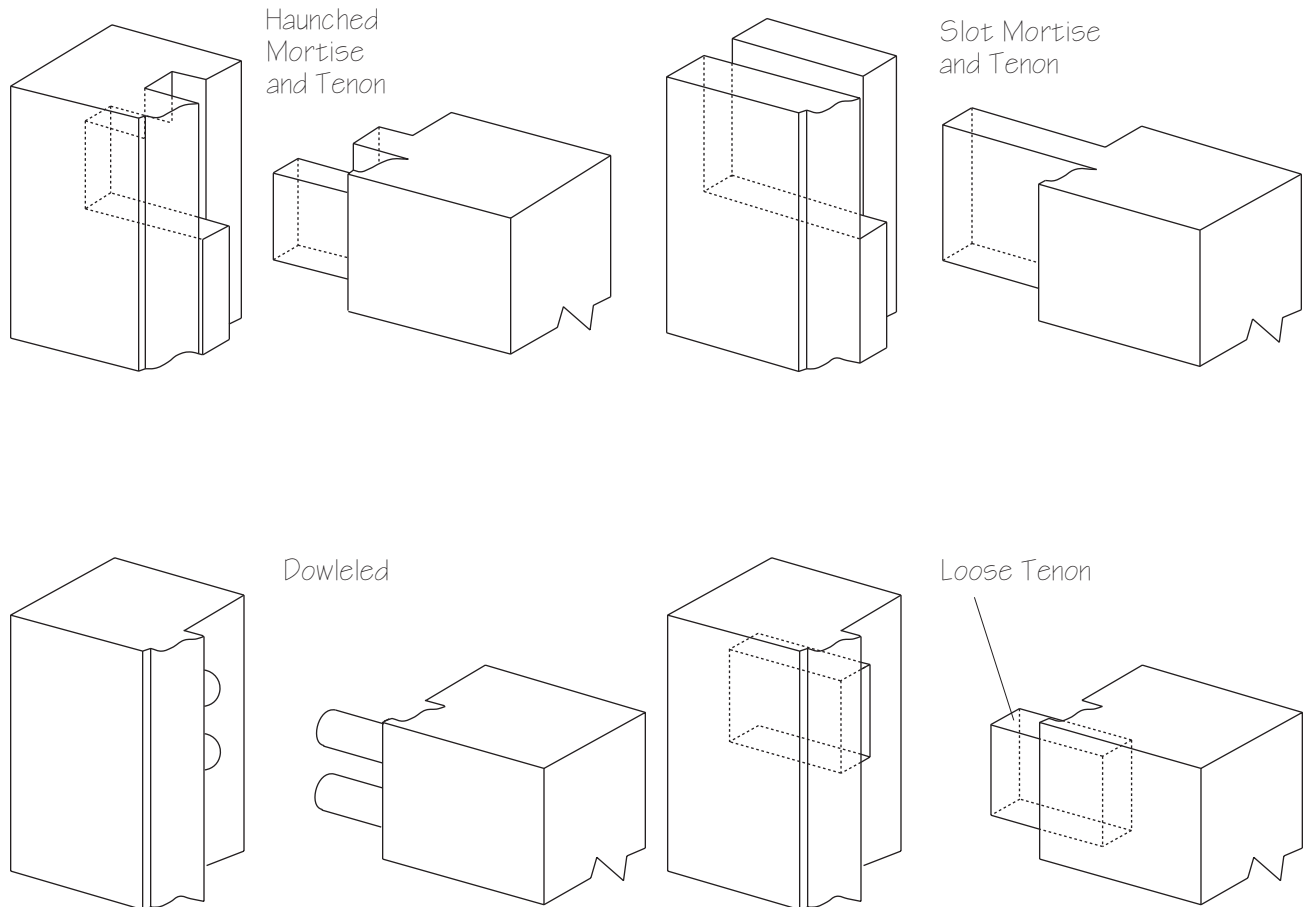

Stile and Rail Joinery Options - Figure 1400-08

1400-S-8

General Moulding Requirements

Species shall match or be compatible with face. Moulding shall be free of open defects, shake, splits, or doze. Moulding must be smooth and free of visible knife, saw, or sanding marks.

1400-S-9

Dimensional Tolerances

Doors Not Prefit

Width: $\pm 1/16$ " [2 mm]

Height: $\pm 1/16$ " [2 mm] Top rail to bottom rail

Note: Stiles (horns) may extend an inch or more beyond the rails, to be trimmed to fit on installation.

Thickness: $\pm 1/16$ " [2 mm]

Doors Machined for Hardware

Width: $\pm 1/32$ " [1 mm]

Height: $\pm 1/16$ " [2 mm]

Thickness: $\pm 1/16$ " [1 mm]

Hardware location: $\pm 1/32$ " [1 mm]

Locks and hinges: $\pm 1/32$ " [1 mm]

Typical Prefit Clearances

Top and hinge edges: $1/8$ " [3 mm]

Single door, lock edge: $1/8$ " [3 mm]

Pair meeting edge: $1/16$ " [2 mm] per leaf

Bottom (rated or non-rated): $1/2$ " [13 mm] from top of decorative floor covering; $3/4$ " [19 mm] maximum from top of non-combustible floor; $3/8$ " [10 mm] maximum from top of noncombustible sill or threshold.

1400-S-10

Smoothness of Exposed Surfaces (Minimum Requirements)

In the absence of specifications, the following sanding standards will apply.

Smoothness Table	Premium		Custom		Economy	
	Transparent	Opaque	Transparent	Opaque	Transparent	Opaque
Flat Surfaces	150 grit		120 grit		100 grit or 15 KCPI	
Moulded Surfaces	120 grit		20 KCPI			
Shaped Surfaces	120 grit		20 KCPI			
Turned Surfaces	120 grit		100 grit			
Sanding Cross Scratches	None allowed	Not to exceed .25" (6 mm)	None allowed	Not to exceed .25" (6 mm)		

NOTE: No tearouts, knife nicks, or hit-or-miss finish allowed. No knife marks allowed where sanding is required. Surface variations as a result of multiple tool passes treated as Turned Surfaces above. Glue and filler, if used, must be inconspicuous and sanded as smoothly as the surrounding surface. Sanding before final stain and/or finish should be a consistent grit and scratch pattern, as it influences blend of color and sheen between components. Turnings are customarily sanded on the lathe, and will exhibit cross scratches. "Eased" edges may or may not be the prevailing practice of the woodworker. Unless specified, the woodworker will furnish material with edges as customary for that plant. Veneer sand-through, with veneer sanded to the point where cross banding or core is visible, is not allowed in any Grade.

1400-S-11

Tightness of Plant Assembled Joints

Plant Assembled Joint Table	Premium		Custom		Economy	
	Interior	Exterior	Interior	Exterior	Interior	Exterior
Maximum Gap: Test A	.015" wide by 20% of joint length	.025" wide by 30% of joint length	.025" wide by 20% of joint length	.050" wide by 30% of joint length	.050" wide by 20% of joint length	.075" wide by 30% of joint length
Maximum Gap: Test B* * typographical correction made-7th ed. 2nd printing	.015" x 3", and no gap may occur within 72" of a similar gap	.025" x 6", and no gap may occur within 30" of a similar gap	.025" x 6", and no gap may occur within 60" of a similar gap	.050" x 8", and no gap may occur within 26" of a similar gap	.050" x 8", and no gap may occur within 48" of a similar gap	.075" x 10", and no gap may occur within 24" of a similar gap
Maximum Gap: Test C	.015"	.025"	.025"	.050"	.050"	.075"
Flushness Variation	.001"	.015"	.005"	.025"	.025"	.050"

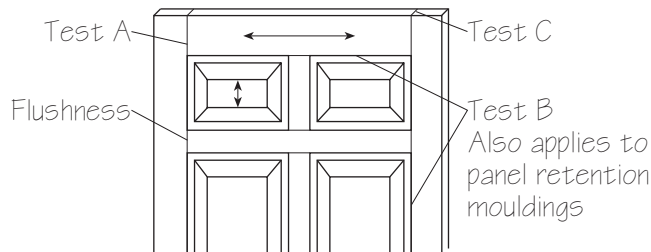

Test Locations - Figure 1400-09

1400-S-12

Selection for Grain and Color

NOTE: For plant assemblies in this section only, when Table(s) in this Section of the Standards are more strict, the Table(s) take precedence over the following:

For Transparent finish, adjacent members shall ...

- Premium Grade: ... be well matched for grain and color.
- Custom Grade: ... be compatible for color.
- Economy Grade: ... not be selected.

Visible finger joints not permitted in Premium and Custom Grades. No selection for grain or color is required for Opaque finish in any Grade.

Field Assemblies

Selection of adjacent members for compatibility is the responsibility of the installation contractor.



Tests

1400-T-1

Tests for Smoothness of Exposed Surfaces

KCPI (Knife Cuts Per Inch) can be determined by holding the surfaced board at an angle to a strong light source and counting the visible ridges per inch, usually perpendicular to the profile.

SANDING can best be checked by sanding a sample piece of the same species with the required grit of abrasive. Observation with a hand lens of the prepared sample and the material in question will offer a comparison of the scratch marks of the abrasive grit. Reasonable assessment of the performance of the finished product will be weighed against absolute compliance with the Standards.

1400-T-2

Tightness and Flushness of Plant Assembled Joints

Joint tightness and/or flushness will meet the standard when tested with a feeler gauge at the points indicated in the illustration. Joint length will be measured with a ruler with a minimum division of $\frac{1}{16}$ " and calculations made accordingly. Reasonable assessment of the performance of the finished product will be weighed against absolute compliance with the Standards.

1400-T-3

Warp

Warp is any distortion in the door itself, and it does not refer to the door in relation to the frame or the jamb in which it is hung. Warp is measured by placing a straight edge or a taut string on the concave face and determining the maximum distance from the straight edge or string to the door face. The accompanying table and drawing illustrate the Standard and Test.

Door Thickness	Door Size	Warp a defect when maximum deviation exceeds
1-3/8" [35 mm]	3'-0" x 7'-0" or smaller [900 x 2100 mm]	1/4" [6 mm]
1-3/4" [44 mm] or thicker	3'-6" x 7'-0" or smaller [900 x 2100 mm]	1/4" [6 mm]
1-3/4" [44 mm] or thicker	Larger than 3'-6" x 7'-0" [900 x 2100 mm]	1/4" [6 mm] in any 3'-6" x 7'-0" section [900 x 2100 mm]
NOTE: 1-3/8" doors are not recommended for sizes in excess of 3'-0" x 7'-0"		

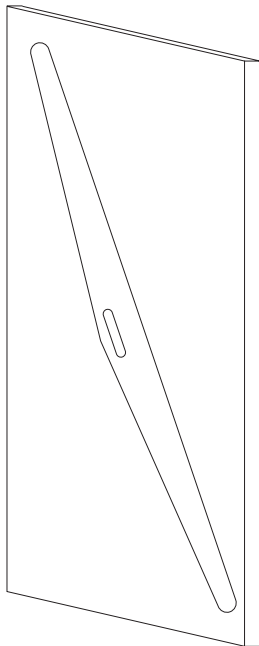

Illustration of Warp Test - Figure 1400-10

1400-T-4

Flushness of Plant Assembled Joints (Maximum Variation in Alignment of Similarly Shaped Surfaces)

Premium Grade

Stiles and Rails - Interior: No variation permitted; Exterior: .015" maximum

Mouldings, beads, rims, etc. - Interior or Exterior: .007" variation maximum

Custom Grade

Stiles and Rails - Interior: .005" maximum; Exterior: .025" maximum

Mouldings, beads, rims, etc. - Interior or Exterior: .015" variation maximum

Economy Grade

Stiles and Rails - Interior: .025" maximum; Exterior: .050" maximum

Mouldings, beads, rims, etc. - Interior or Exterior: .030" variation maximum

1400-T-5

Show-through or Telegraphing

Telegraphing is any distortion in the face veneer of a door caused by variations in thickness between the core materials and/or the vertical or horizontal edge bands. In any Grade, variation from a true plane in excess of 0.010" in any 3" [76 mm] span is considered a defect. The accompanying table and drawing illustrate the standard and test. (The selection of high gloss finishes should be avoided because they tend to accentuate natural variations in material and construction.)

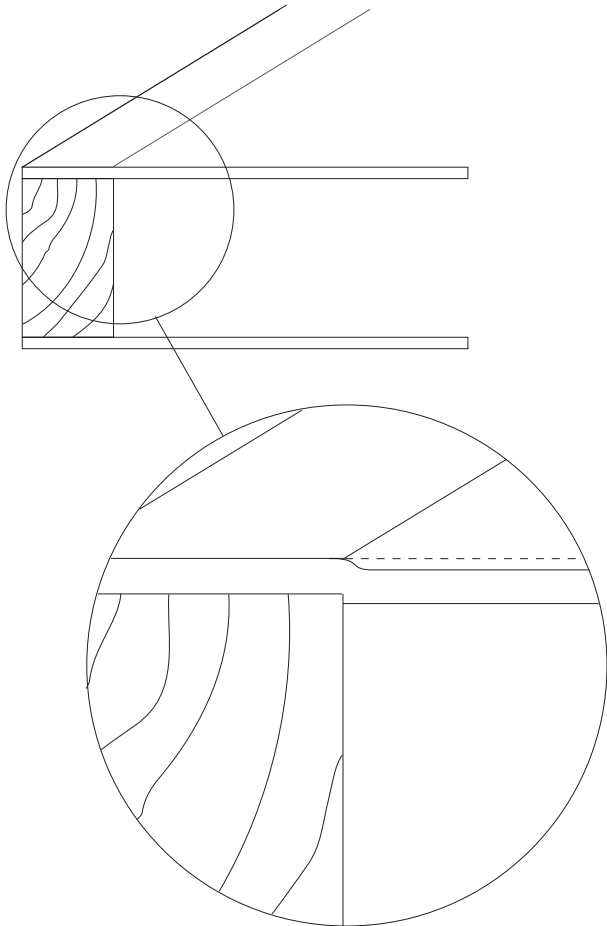

Illustration of Show-through Test - Figure 1400-11



Design Ideas

1400-D

Freedom of Expression

This section is full of design ideas. It makes no pretense of being complete. It's here for the reader to use as a starting place. The exercise of personal creativity is the essence of fine architectural woodworking.

Custom-designed woodwork gives you complete freedom of expression.

- **Design Flexibility:** The use of custom designed woodwork in a building allows the design professional freedom of expression while meeting the functional needs of the client. A custom designed building is enhanced by the use of custom designed woodwork.
- **Cost Effective:** Custom woodwork does compete favorably with mass-produced millwork, and offers practically limitless variations of design and material. Most woodwork lasts the life of the building—quality counts.
- **Complete Adaptability:** By using custom woodwork, the architect or designer can readily conceal plumbing, electrical and other mechanical equipment without compromising the design criteria.
- **No Restrictions:** Custom architectural woodwork permits complete freedom of selection of any of the numerous hardwoods and softwoods available for transparent or opaque finish. Other unique materials available from woodwork manufacturers require no further finishing at all, such as plastic laminates and decorative overlays. These materials can be fashioned into a wide variety of profiles, sizes, and configurations. The owner and design professional have the best of both worlds—high quality and freedom of choice.
- **Dimensional Flexibility:** Since custom woodwork is normally produced by a specialty architectural woodwork firm, dimensions can easily be changed prior to actual fabrication if required by job conditions. Special situations such as designing for the handicapped can readily be accommodated by the custom architectural woodwork manufacturer.
- **Quality Assurance:** Adherence to the AWI Quality Standards will help guarantee the design professional of a quality product at a competitive price. Use of a qualified AWI member firm will help insure the woodworker's understanding of the quality level required. Specifying that the woodwork be certified under the AWI National Quality Certification Program is the best guarantee of compliance with the Quality Standards and the project specifications.

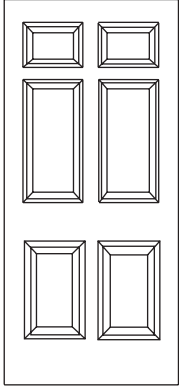

Fig. 1400-D-1

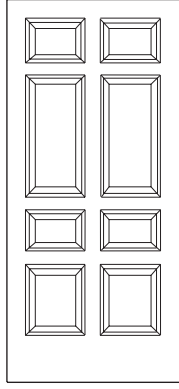

Fig. 1400-D-2

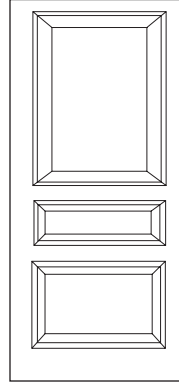

Fig. 1400-D-3

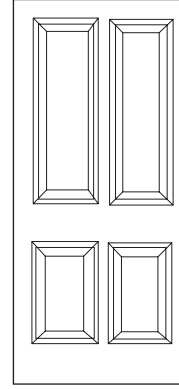

Fig. 1400-D-4

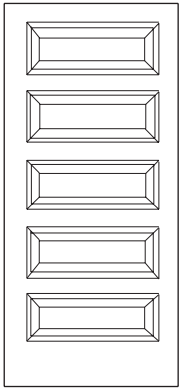

Fig. 1400-D-5

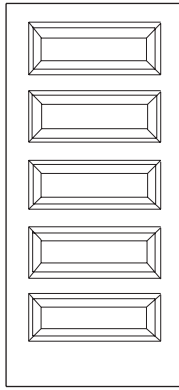

Fig. 1400-D-6

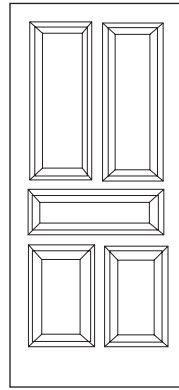

Fig. 1400-D-7

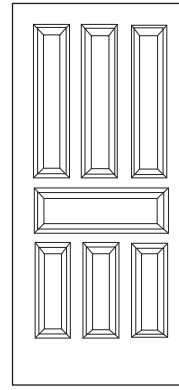

Fig. 1400-D-8

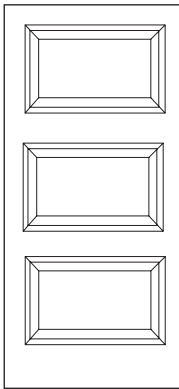

Fig. 1400-D-9

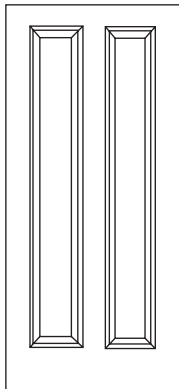

Fig. 1400-D-10

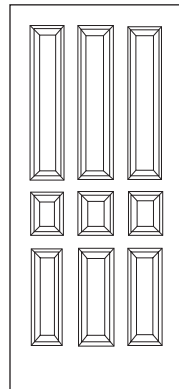

Fig. 1400-D-11

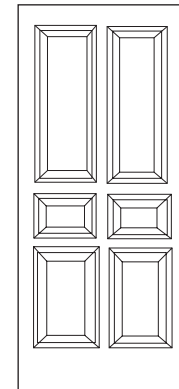

Fig. 1400-D-12

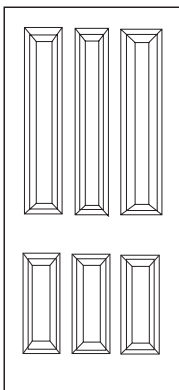

Fig. 1400-D-13

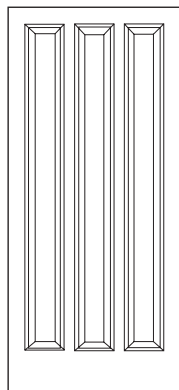

Fig. 1400-D-14

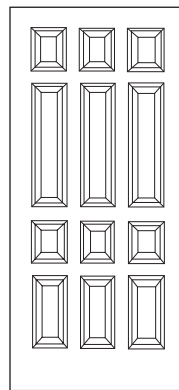

Fig. 1400-D-15

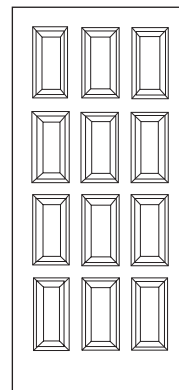

Fig. 1400-D-16

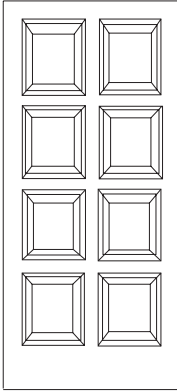

Fig. 1400-D-17

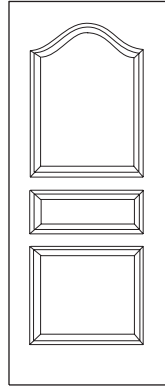

Fig. 1400-D-18

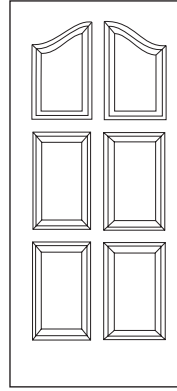

Fig. 1400-D-19

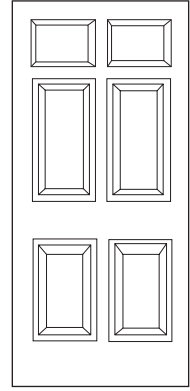

Fig. 1400-D-20

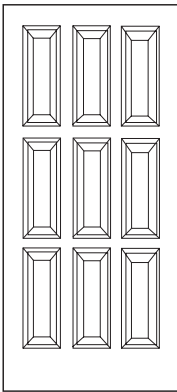

Fig. 1400-D-21

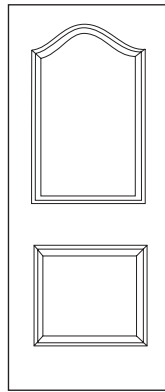

Fig. 1400-D-22

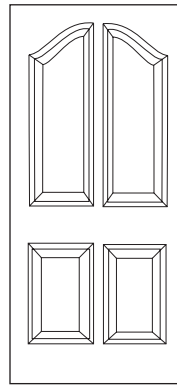

Fig. 1400-D-23

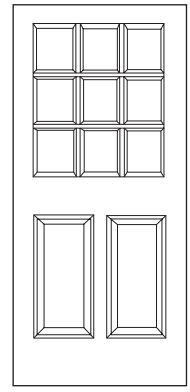

Fig. 1400-D-24

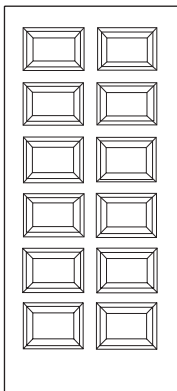

Fig. 1400-D-25

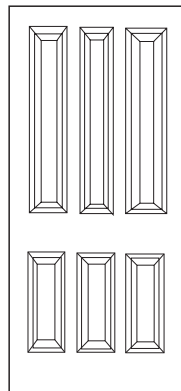

Fig. 1400-D-26

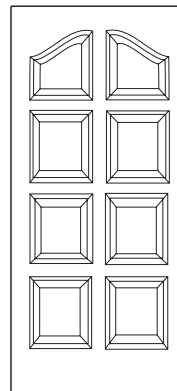

Fig. 1400-D-27

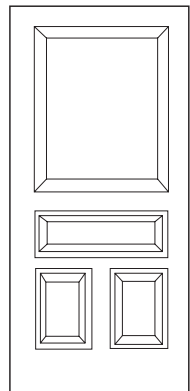

Fig. 1400-D-28

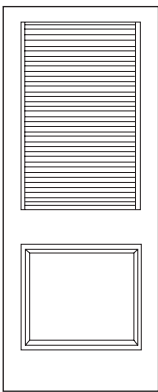

Fig. 1400-D-29

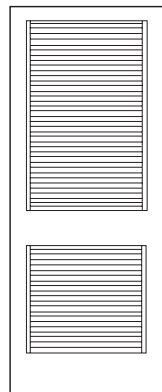

Fig. 1400-D-30

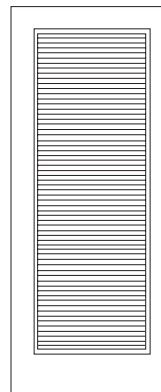

Fig. 1400-D-31

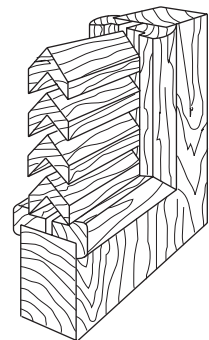

Fig. 1400-D-32

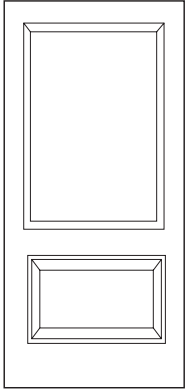

Fig. 1400-D-33

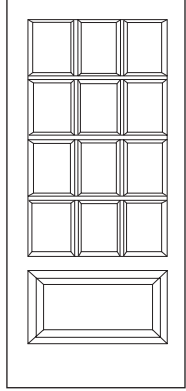

Fig. 1400-D-34

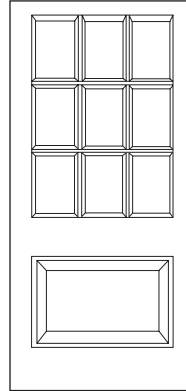

Fig. 1400-D-35

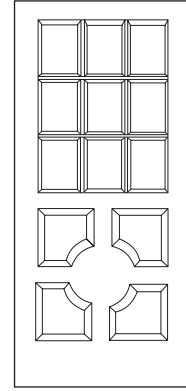

Fig. 1400-D-36

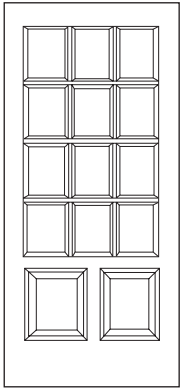

Fig. 1400-D-37

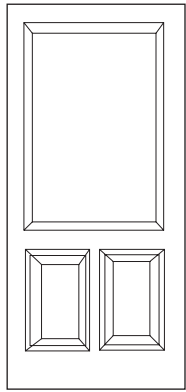

Fig. 1400-D-38

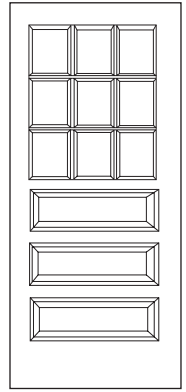

Fig. 1400-D-39

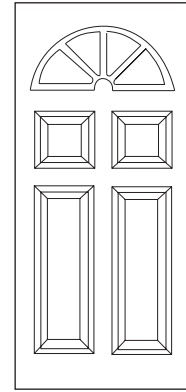

Fig. 1400-D-40

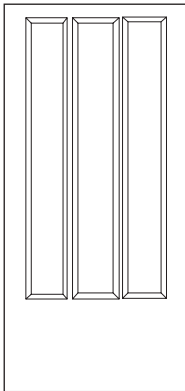

Fig. 1400-D-41

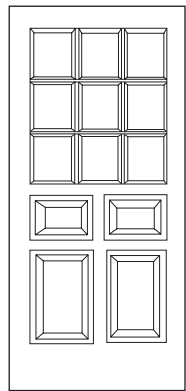

Fig. 1400-D-42

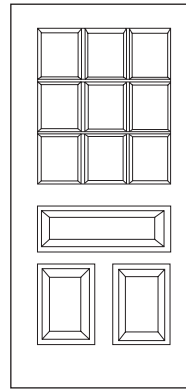

Fig. 1400-D-43

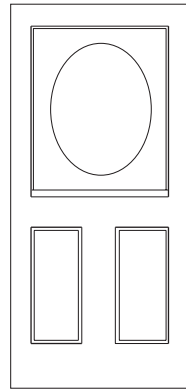

Fig. 1400-D-44

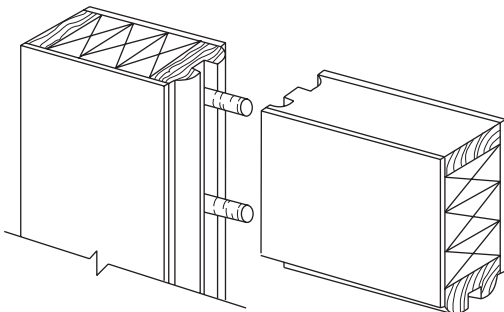

Fig. 1400-D-45

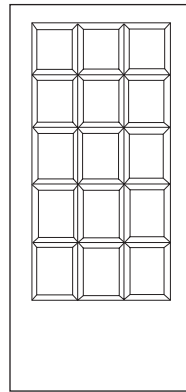

Fig. 1400-D-46

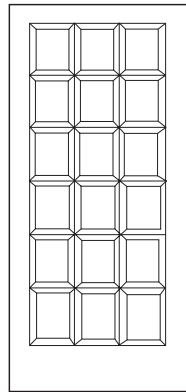

Fig. 1400-D-47

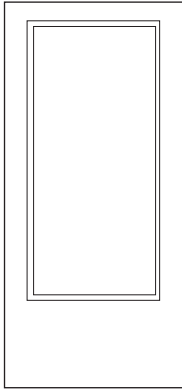

Fig. 1400-D-48

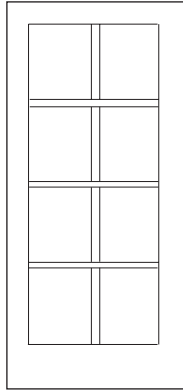

Fig. 1400-D-49

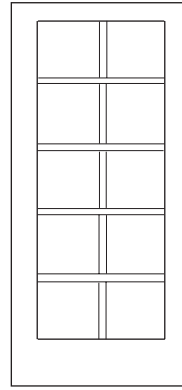

Fig. 1400-D-50

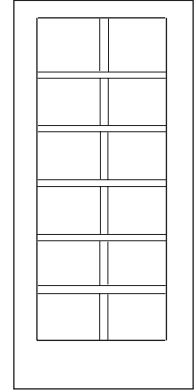

Fig. 1400-D-51

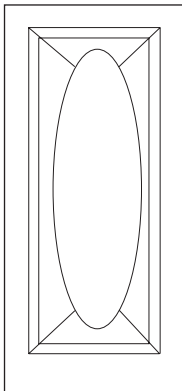

Fig. 1400-D-52

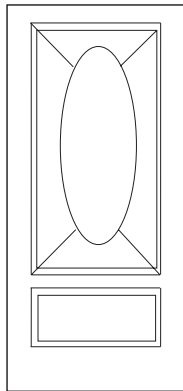

Fig. 1400-D-53

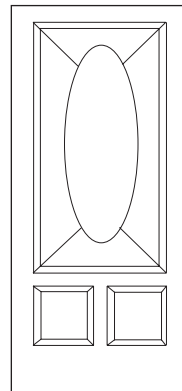

Fig. 1400-D-54

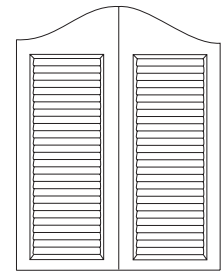

Fig. 1400-D-55